

CABLE ASSEMBLY INSTRUCTIONS

Right angle type connectors(1)

H

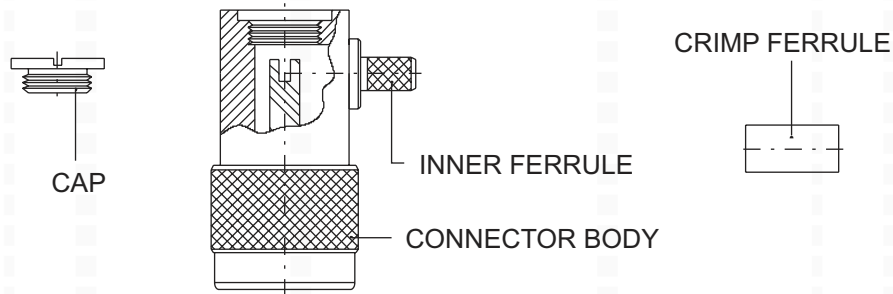

1.



Preparation of cable

- (1) Slide crimp ferrule onto cable.
- (2) Strip cable to recommended dimensions shown in catalogue.

2.

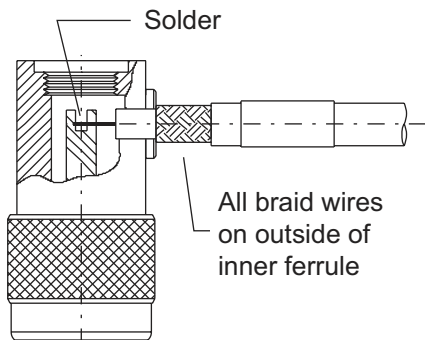

Solder center contact to cable center conductor

- (1) Insert cable into connector body with center conductor placed in contact slot, and with all braid wires on outside of inner ferrule.
- (2) Soft solder center contact to cable center conductor.

3.

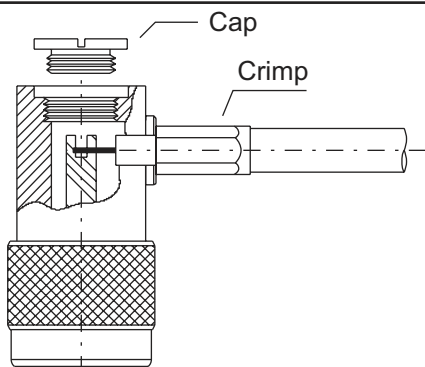

Final assembly

- (1) Slide crimp ferrule forward until flush with connector body and crimp.
- (2) Screw cap into opening in rear of connector body until it stops.

Note: